

6 PLAN - SIDE YARD AT LOTS 3-4, 3-5 LOTS 1-4, 1-5 G.M.  
1/8" = 10'

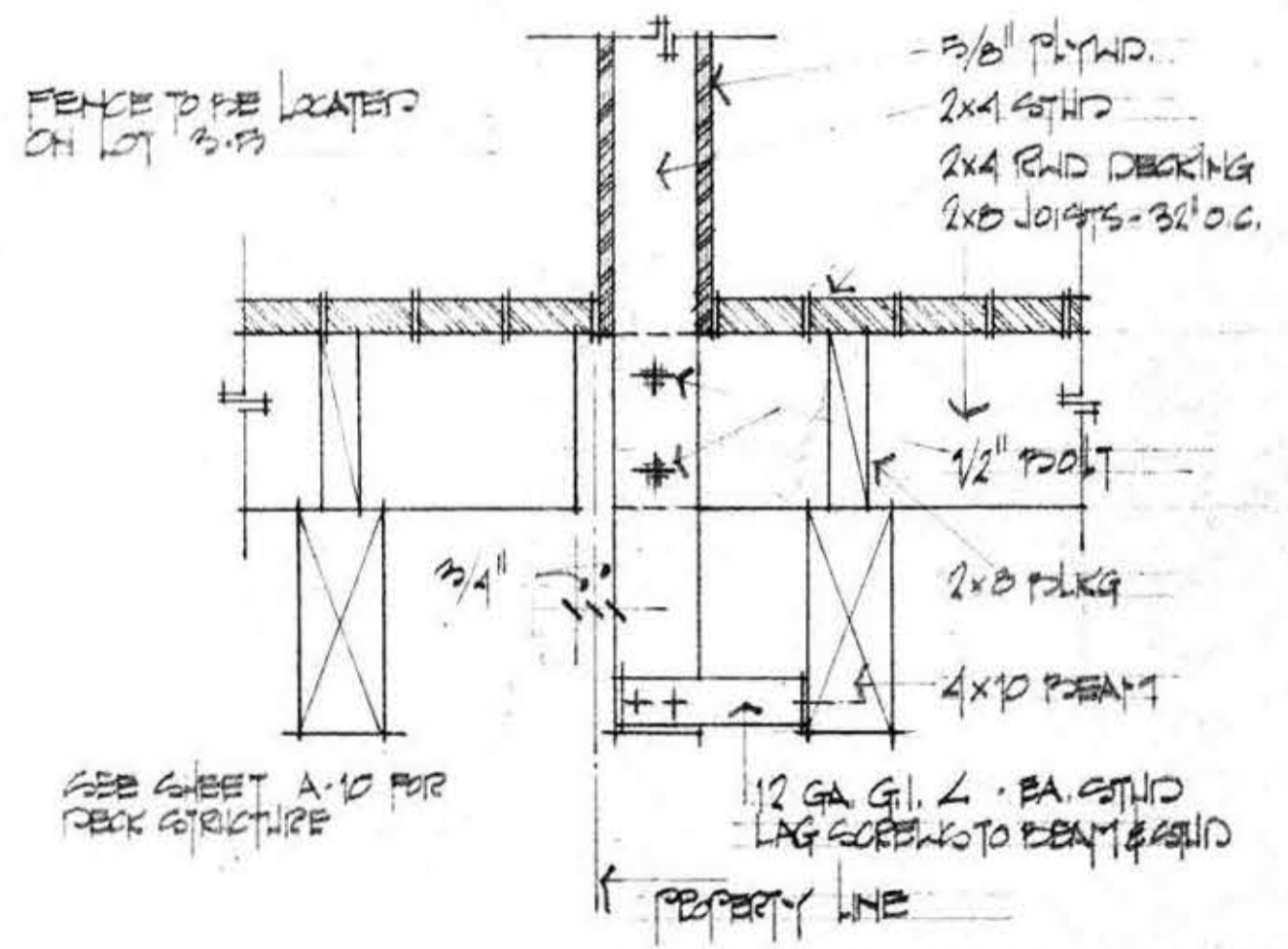

7 SECTION THRU FENCE  
1/2" = 10'

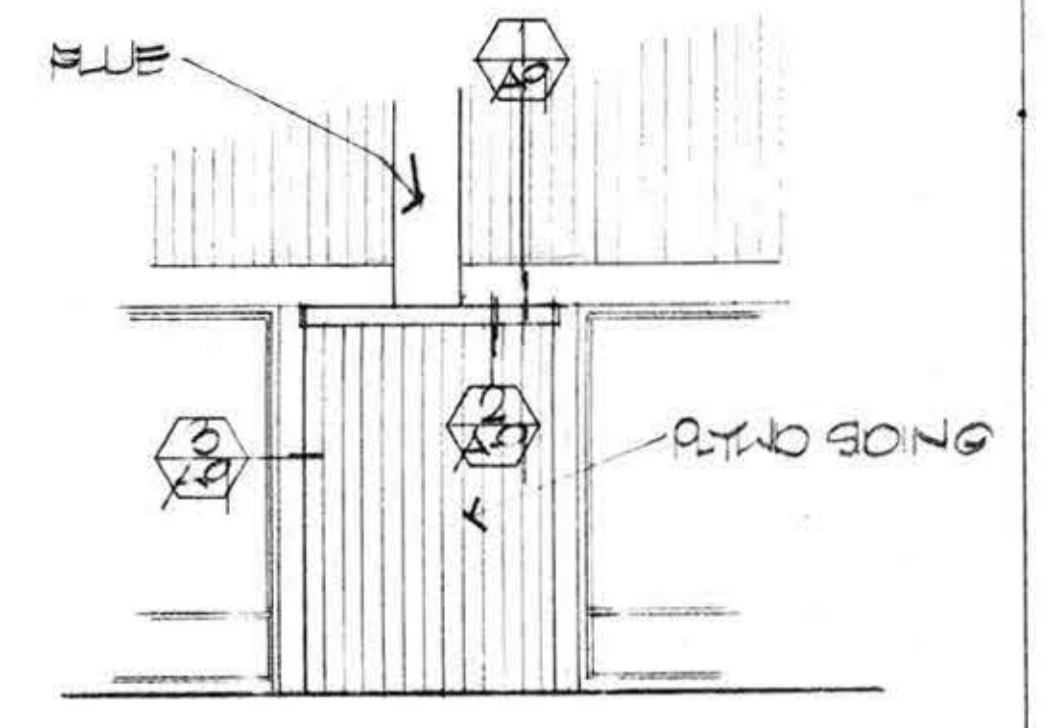
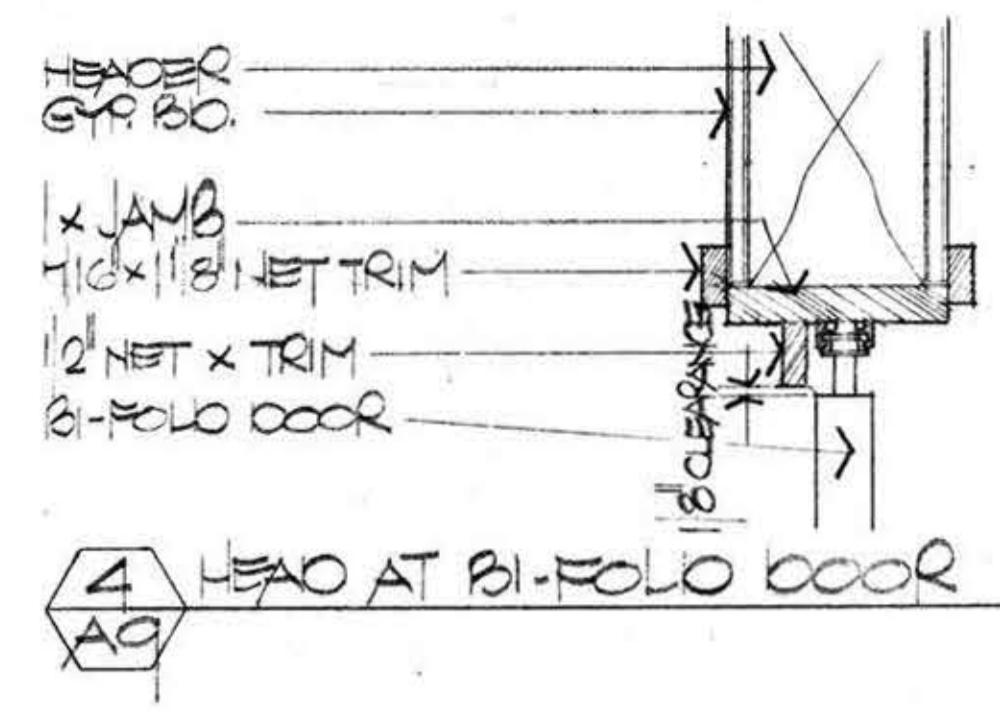

REVISED TYPICAL FIREPLACE HOUSING ELEV. - ALL UNITS

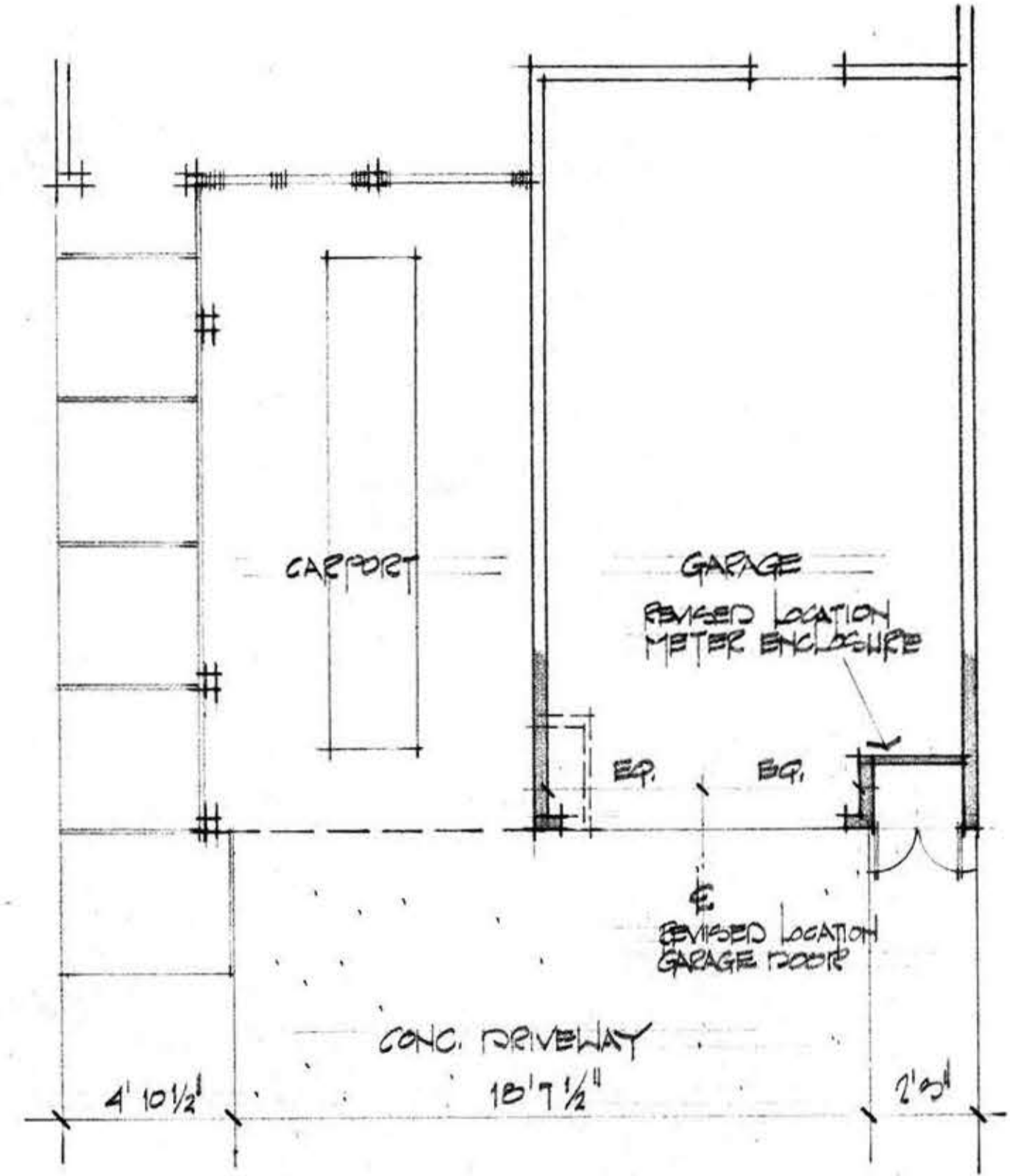

5 REVISED LOCATION - METER ENCLOSURE  
1/4" = 10'  
TYPICAL AT ALL 931 & 941 UNITS

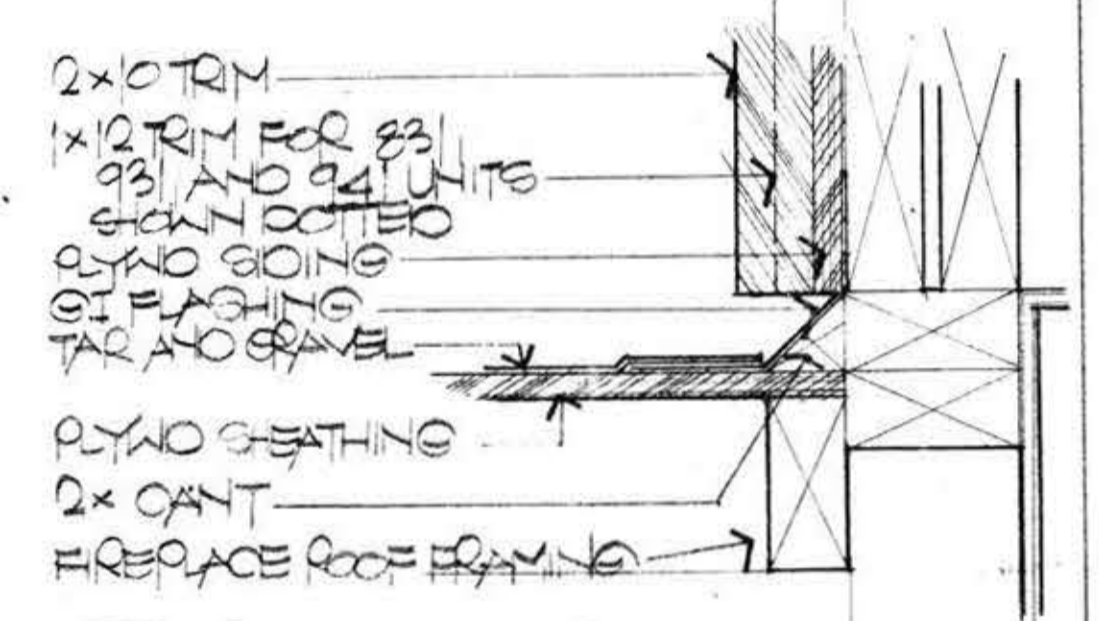

1 ROOF DETAIL  
A9 830, 840, 110 & 843 UNITS

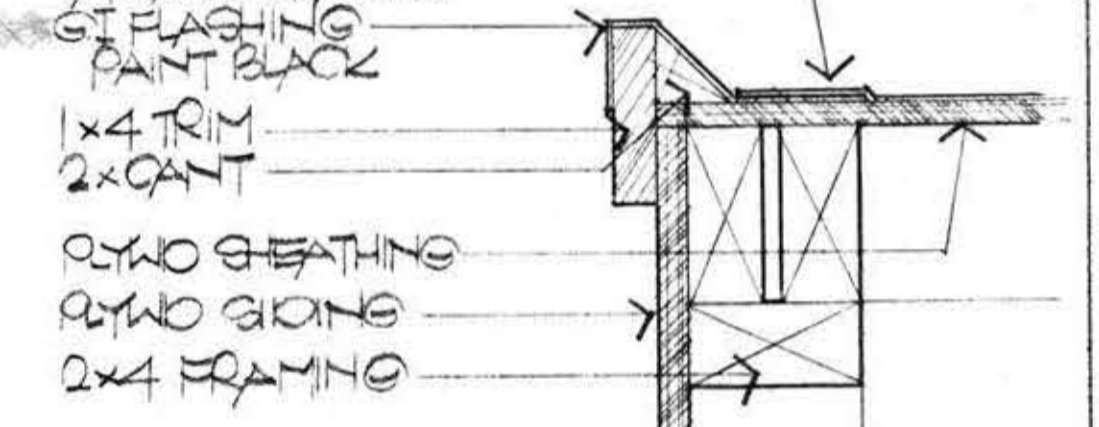

2 TYPICAL ROOF DETAIL  
A9 ALL UNITS  
MITER CORNER

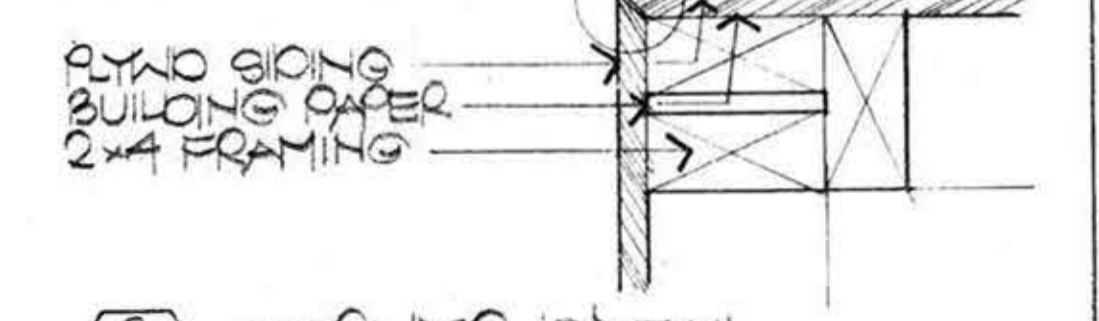

3 CORNER DETAIL  
A9 ALL UNITS

REVISED 15 OCT. 69 - DETAILS 13, 6, 7 ADDED

JOB NO 6802 DATE 14 AUG 1969	BALLENA BAY TOWNHOUSES ALAMEDA CALIFORNIA	FISHER • FRIEDMAN • ASSOCIATES • A.I.A. ARCHITECTS AND PLANNING CONSULTANTS ROBERT J. GREENING A.I.A. • ASSOCIATE 140 CALIFORNIA STREET • SAN FRANCISCO • CALIFORNIA	SHEET A9
---------------------------------------	--	---	-------------